

EC Single Inlet Blower

Φ160

EC单进风鼓风机



Impeller: Metal sheet
shell: Metal sheet and coated in black
Motor: EC brushless external rotor motor
Insulation: Class B
Approvals: CE;UL is in process
Operating Temperature: -20~+60°C
Technical Features:Control input 0-10VDC/PWM, tach output.Locked rotor protection,reverse polarity. Current limited,soft start

叶轮材质: 金属钢
 外壳材质: 金属钢及表面烤黑漆
 电机类型: EC无刷外转子电机
 绝缘等级: Class B
 产品符合的认证: CE;UL申请中
 工作温度: -20~+60°C
 技术特性: 调速输入0-10VDC/PWM, 调速信号输出, 堵转, 极性、限流保护, 软启动

技术参数 Specifications

Listed Model 产品型号	Rated Voltage 额定电压	Operating Voltage 工作电压	Rated Current 额定电流	Rated Power 额定功率	Rated Speed 额定转速	Air Flow 风量		Air Pressure 风压		Noise Level 噪音	Net Weight 重量
Part NO.	VAC	VAC	A	W	RPM	CFM	m ³ /h	mmH ₂ O	inH ₂ O	dBA	Kg
PB1E16062HB2M-B	115	92~132	2.8	180.0	2,150	370	628.4	50.8	2	70	3.5
PB2E16062HB2M-B	230	184~265	1.4	180.0	2,150	370	628.4	50.8	2	70	3.5

外形 Outline

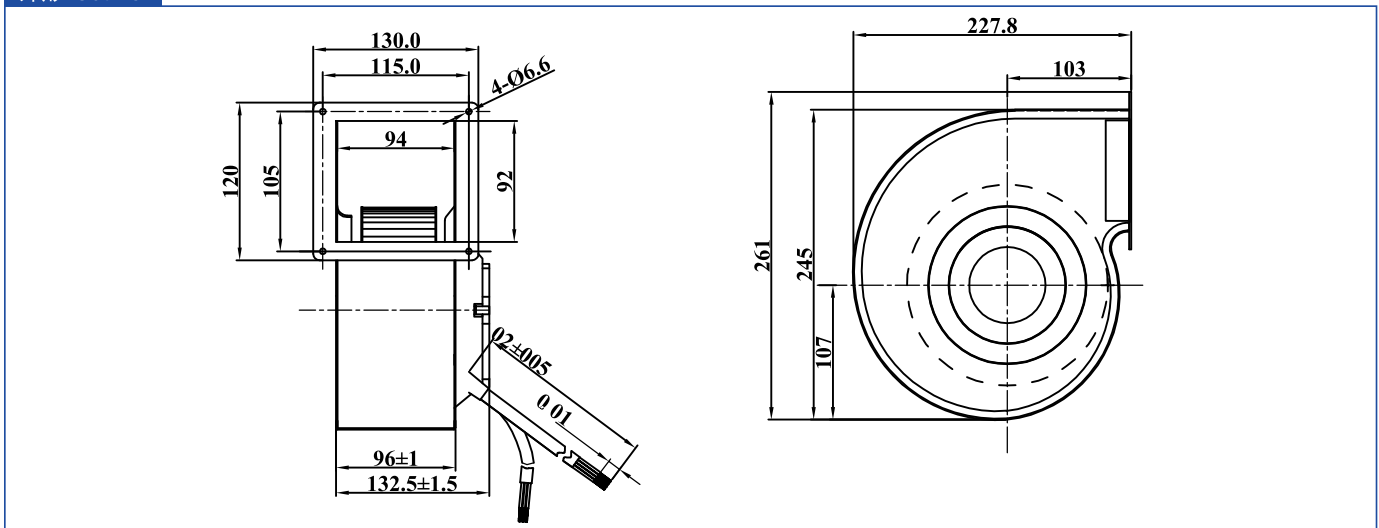

曲线 Curves

