

EC Axial Fan

Φ 300

EC轴流风机



Impeller: Metal sheet and coated in black
Motor: EC brushless external rotor motor
Insulation: Class B
Approvals: CE; UL E306337
Operating Temperature: -20~+60°C
Technical Features: Control input 0-10VDC/PWM, tach output. Locked rotor protection, reverse polarity. Current limited, soft start

叶轮材质: 金属钢及表面烤黑漆
 电机类型: EC无刷外转子电机
 绝缘等级: Class B
 产品符合的认证: CE; UL E306337
 工作温度: -20~+60°C
 技术特性: 调速输入0-10VDC/PWM, 调速信号输出, 堵转, 极性、限流保护, 软启动

技术参数 Specifications

Listed Model 产品型号	Rated Voltage 额定电压	Operating Voltage 工作电压	Rated Current 额定电流	Rated Power 额定功率	Rated Speed 额定转速	Air Flow 风量		Air Pressure 风压		Noise Level 噪音	Net Weight 重量
						CFM	m ³ /h	mmH ₂ O	inH ₂ O		
Part NO.	VAC	VAC	A	W	RPM	CFM	m ³ /h	mmH ₂ O	inH ₂ O	dBA	Kg
PF1E300111HB2M-A	115	92~132	1.2	65.0	1,650	1269.5	2156.2	18.96	0.75	63	2.4
PF2E300111HB2M-A	230	184~265	0.6	65.0	1,650	1269.5	2156.2	18.96	0.75	63	2.4
PF1E300111UB2M-A	115	92~132	2.5	155.0	2,300	1769.6	3005.3	36.7	1.45	67	2.4
PF2E300111UB2M-A	230	184~265	1.25	155.0	2,300	1769.6	3005.3	36.7	1.45	67	2.4

外形 Outline

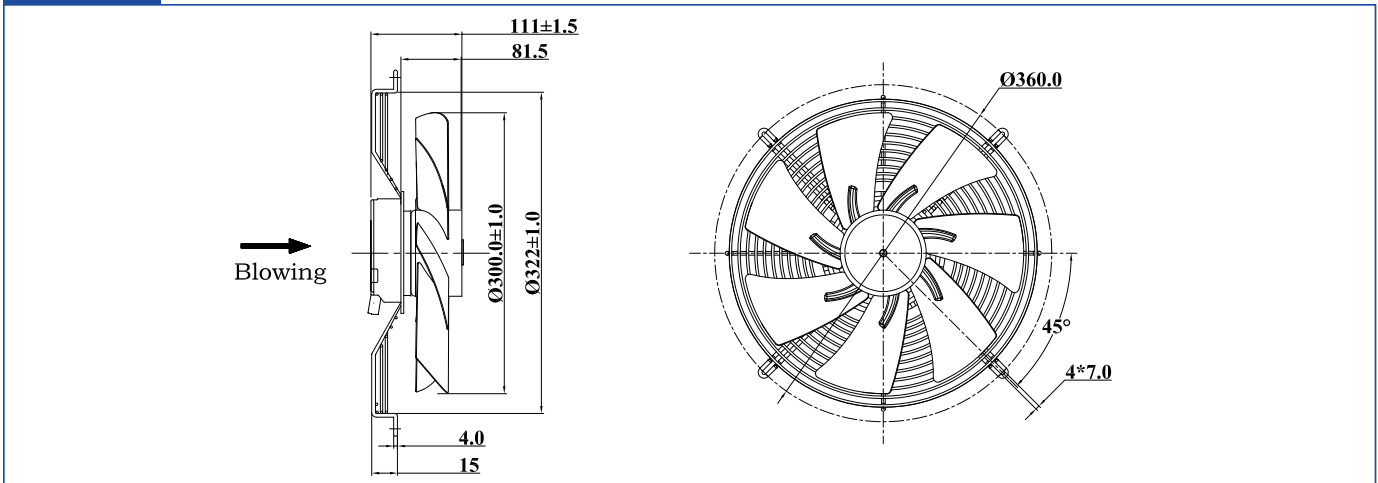

曲线 Curves

